



Saturno Special 2 Operating Procedures

REA North America

December 2005

REA - Saturno Special 2 INTRODUCTION

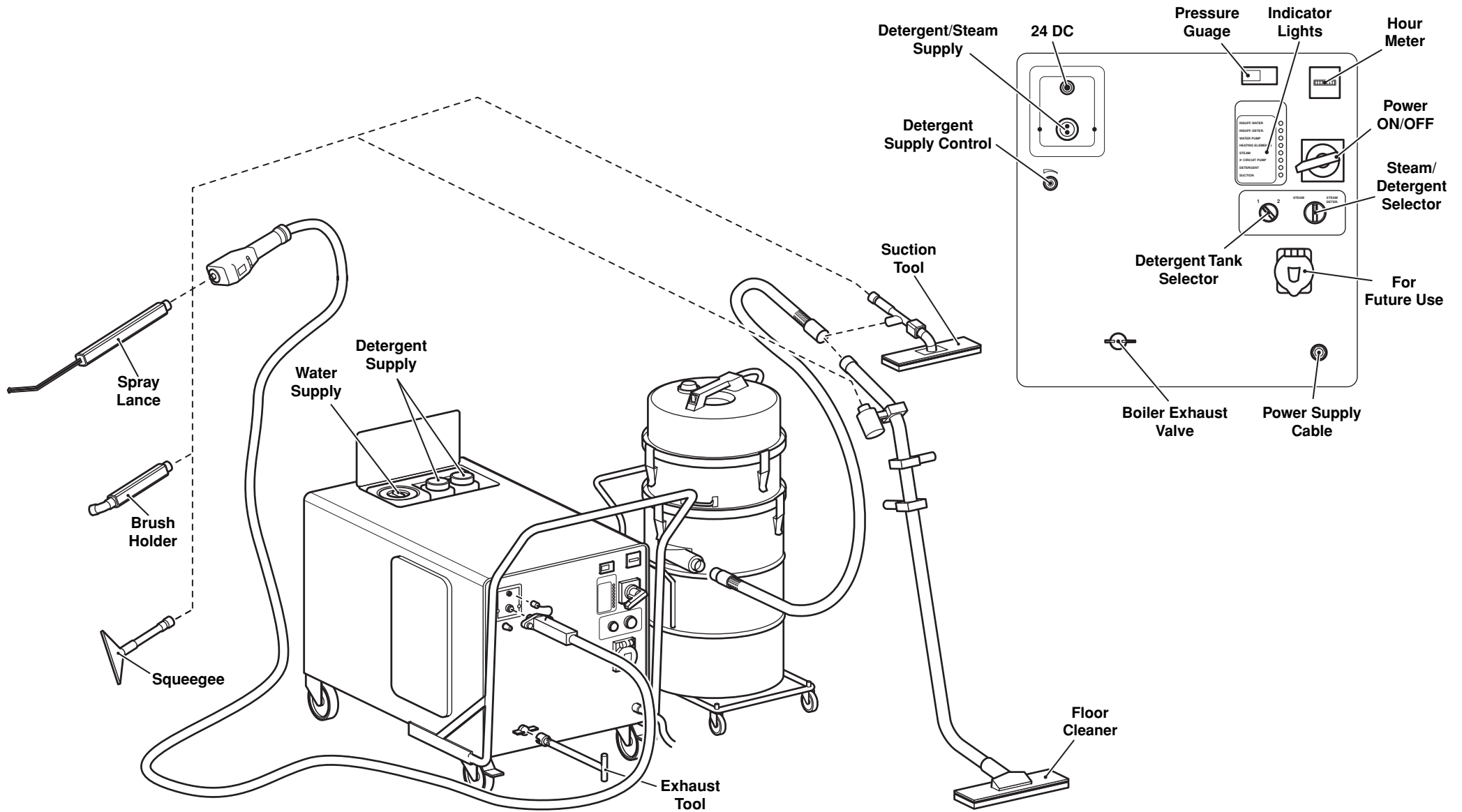

REA - Saturno Special 2 HAZARDS

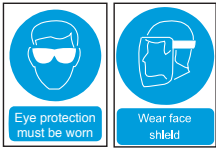

Wear Safety Glasses or Face Shield



Wear Ear Protection



Wear Gloves



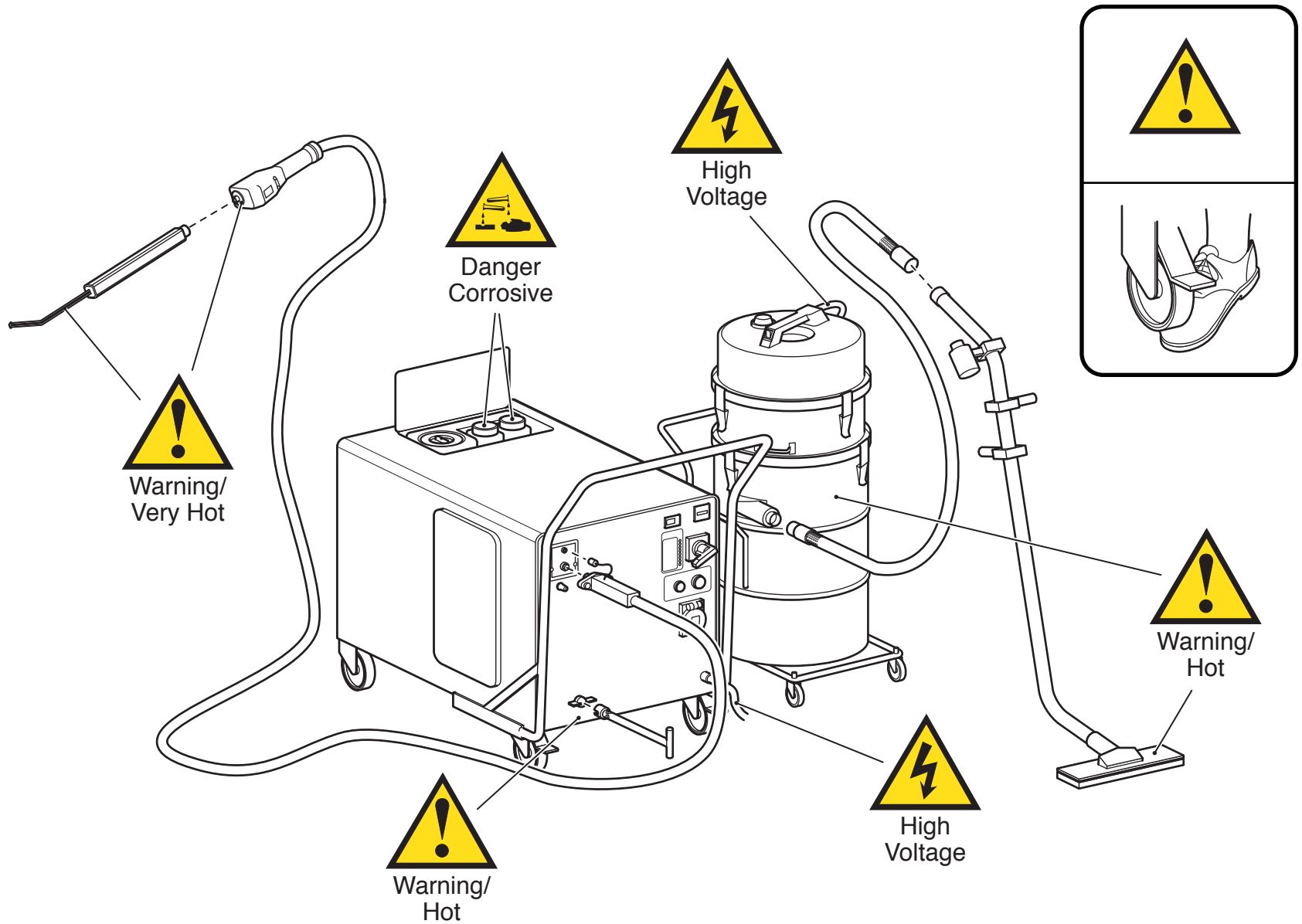

Safety Shoes/Boots



REA - Saturno Special 2 ADDITION OF DETERGENT

Key

-  Set/Move
-  Remove/Replace
-  Release/Secure

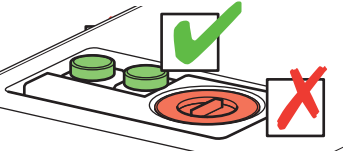

Attention: Do not put detergent or other contaminants in water tank. If this occurs do not turn unit on (or shut off immediately if unit is on) and refer to trouble shooting section.

1.

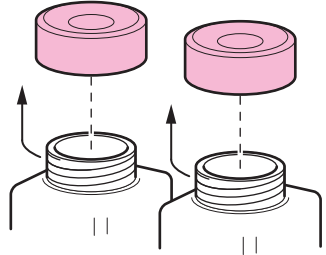

Carefully release and remove the lid/lids.

2.

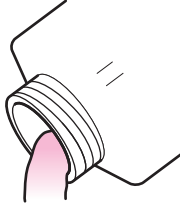

If you are to use a different detergent dispose of any remaining detergent appropriately.

3.

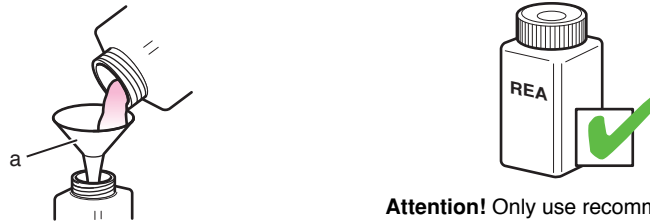

Carefully fill each cartridge with the appropriate detergent using a funnel (a).

Attention! Only use recommended products from REA. Do not use other substances without conferring with REA North America.



4.

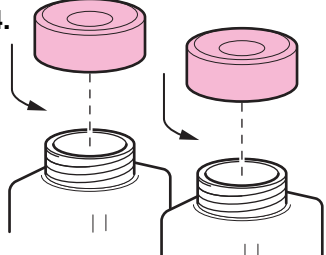

Carefully replace and secure the lid/lids.

REA - Saturno Special 2 ADDITION OF WATER

Key

- Set/Move
- Remove/Replace
- Release/Secure

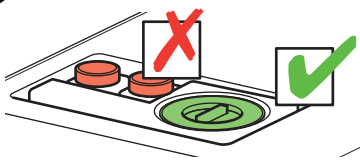

Attention: Do not put detergent or other contaminants in water tank. If this occurs do not turn unit on (or shut off immediately if unit is on) and refer to trouble shooting section.

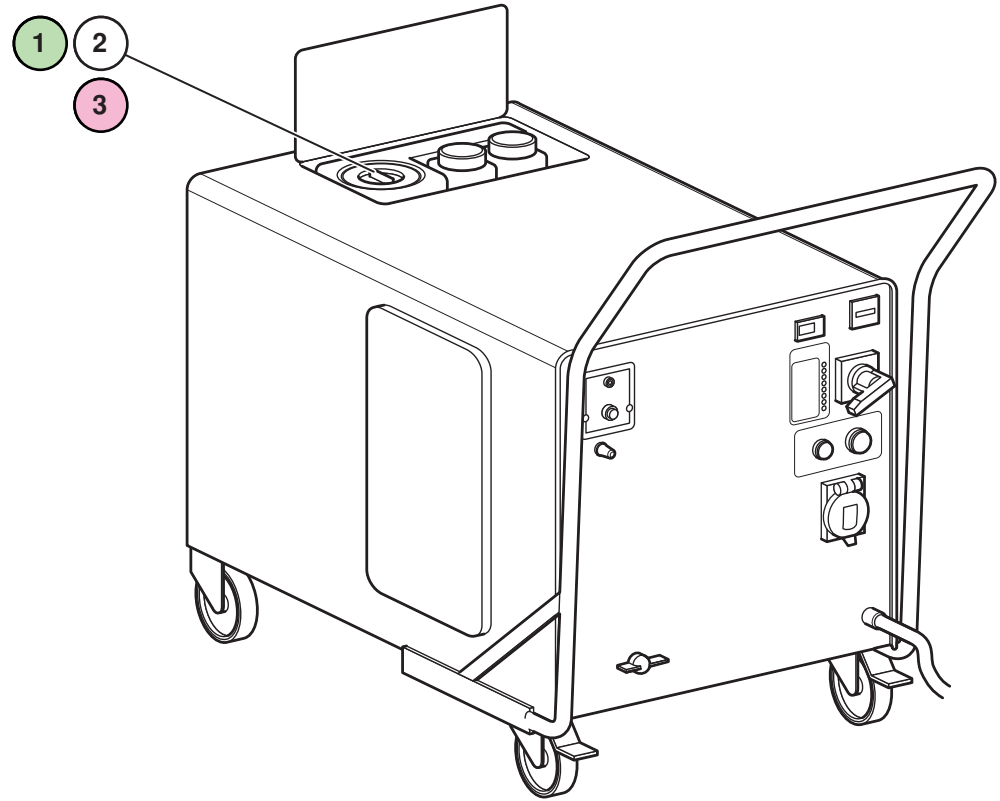

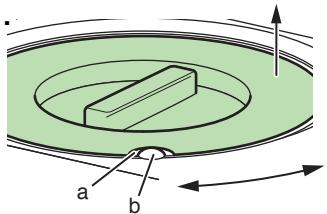

Attention: Do not use dirty pails, hoses or funnels to fill water tank. Do not use detergent funnel for filling of water tank.

1.

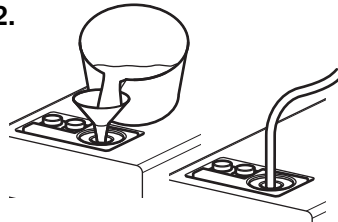

Rotate lid of water tank until the gap (a) aligns with one of the screws (b) and remove lid.

2.



Add clean cold water from an approved source.

3.

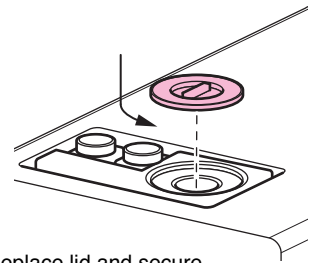

Replace lid and secure.

REA - Saturno Special 2 INITIAL CHECKS

Key

- Set/Move
- Remove/Replace
- Release/Secure

1.

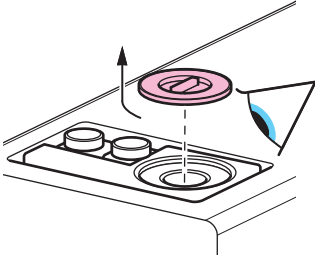

Check that your water tank is full.

2.

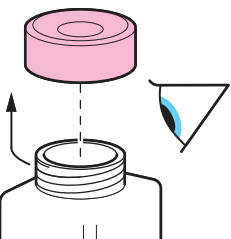

Check that your detergent cartridge is full.

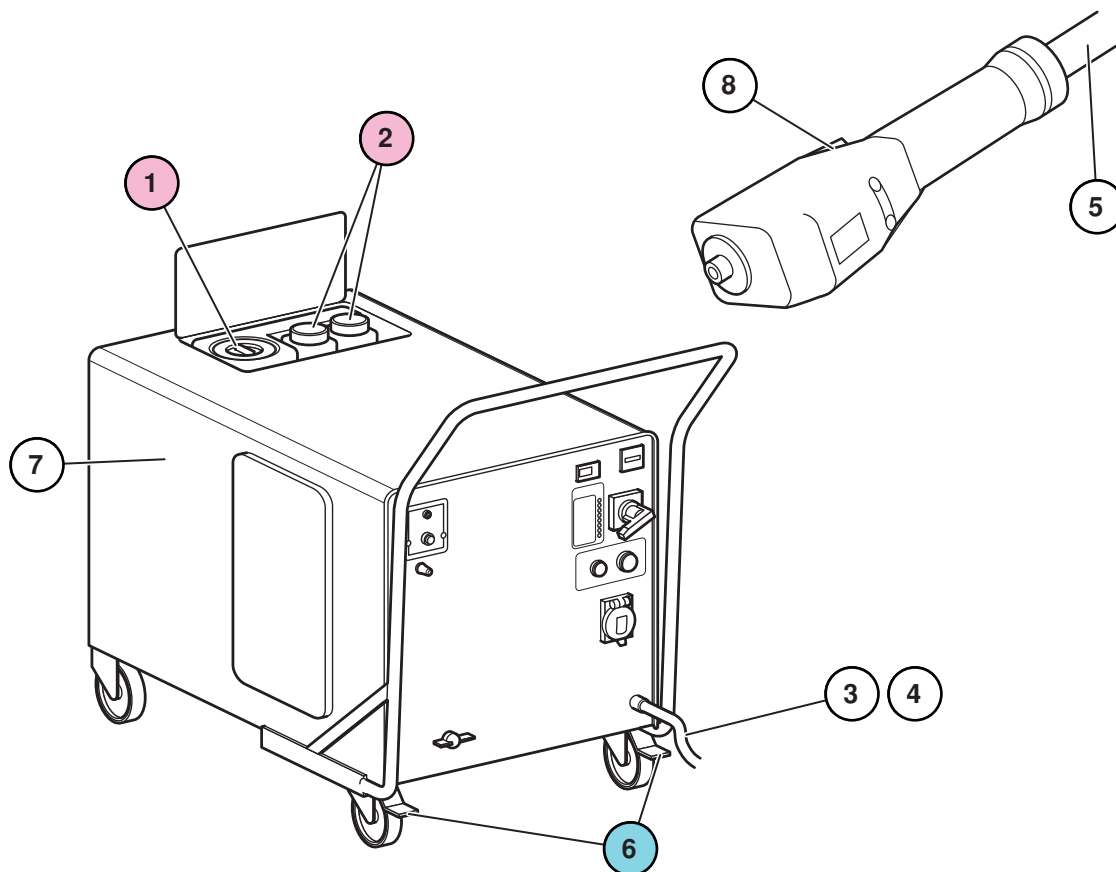

8.

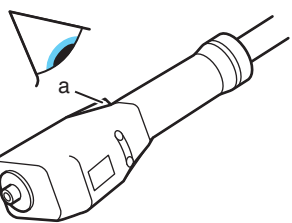

Ensure the handle switch (a) is not depressed.

7.

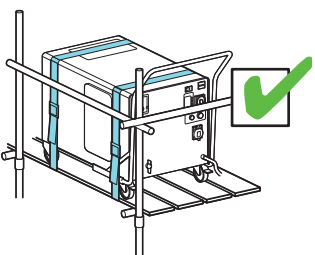

Ensure machine is appropriately anchored.

3.



Ensure there is no risk of trip entanglement on electrical cord.

4.

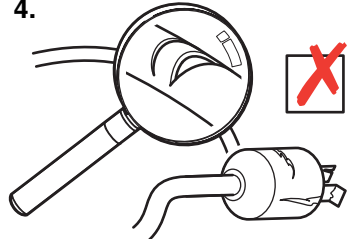

Check condition of power cord and plug for damage.

5.

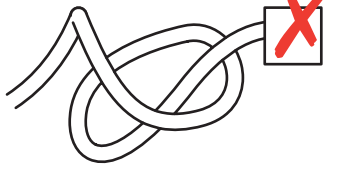

Ensure there are no kinks in the steam hose.

6.

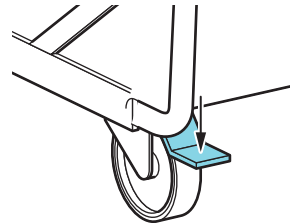

Apply front brakes.

REA - Saturno Special 2 ASSEMBLY OF ACCESSORIES

Key

- Set/Move
- Remove/Replace
- Release/Secure

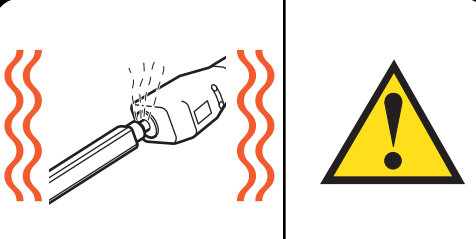

Warning:
Steam will escape from loose accessory connections

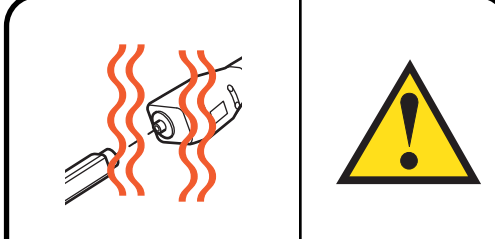

Warning:
Threaded end of handle can be hot

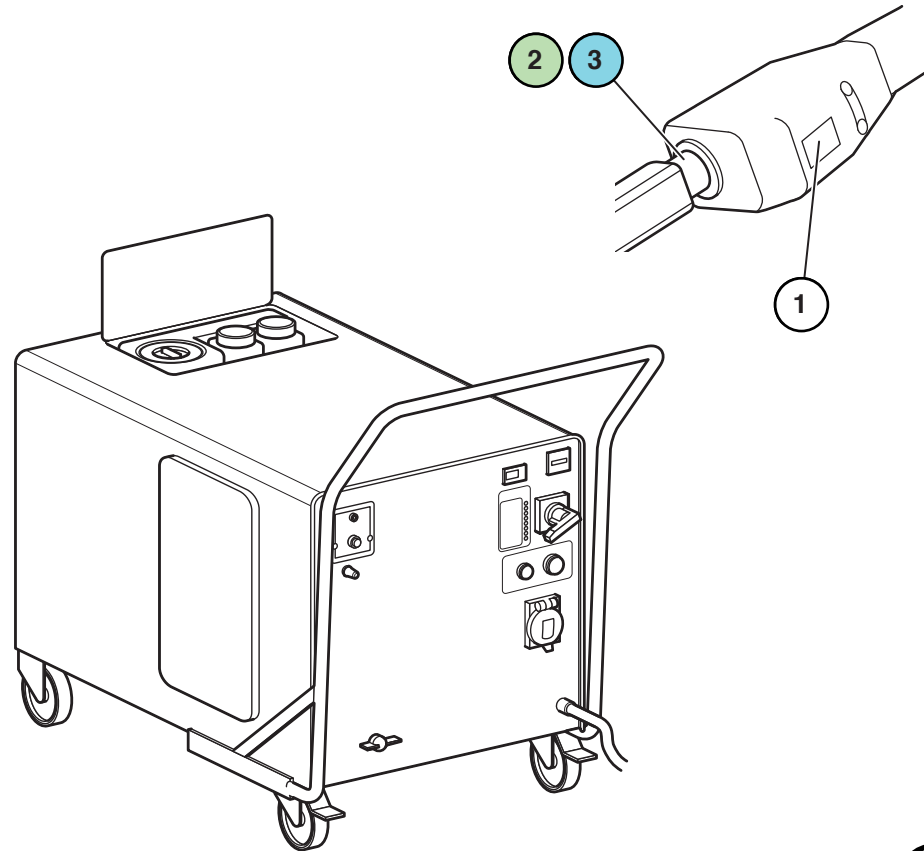

1.

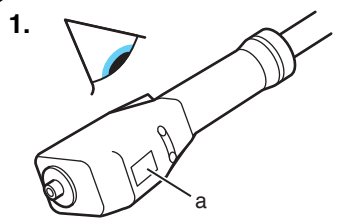

NEVER assemble/disassemble attachments without digital readout (a) set to zero.

2.

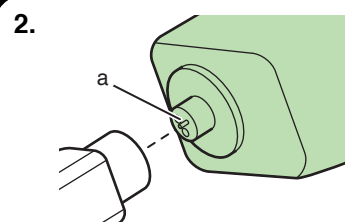

Fit locator pin (a) on handle into hole on accessory to seat pieces.

3.

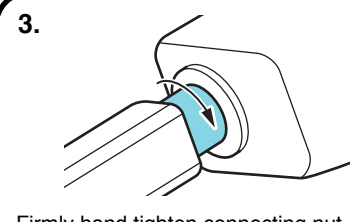

Firmly hand tighten connecting nut clockwise. If steam escapes from tightened connection please refer to trouble shooting section.



Note.



Steam supply is regulated by the switch on the control Handle.
 0 = OFF.
 1 = Steam Only.
 2 = Steam Water and Detergent.
 3 = Steam and Water.
 4 = Steam Water Detergent & Vacuum.
 5 = Steam and Vacuum.
 6 = Vacuum Only.

REA - Saturno Special 2 START UP

Key

-  Set/Move
-  Remove/Replace
-  Release/Secure

1.

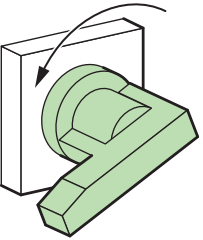

Ensure the main power switch is in the 'Off' position.

2.

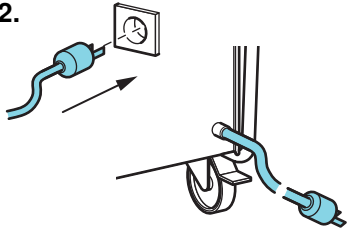

Plug main power cord into electrical outlet.

3.

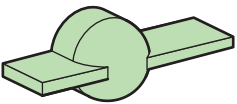

Check that the boiler exhaust valve is in the closed position.

4.

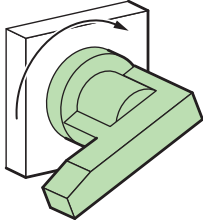

Turn 'On' the main power switch.

5.

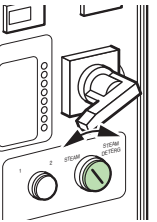

Select 'STEAM' (steam only) or 'STEAM DETERG' (steam and detergent).

6.

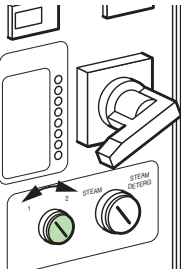

Select detergent tank.

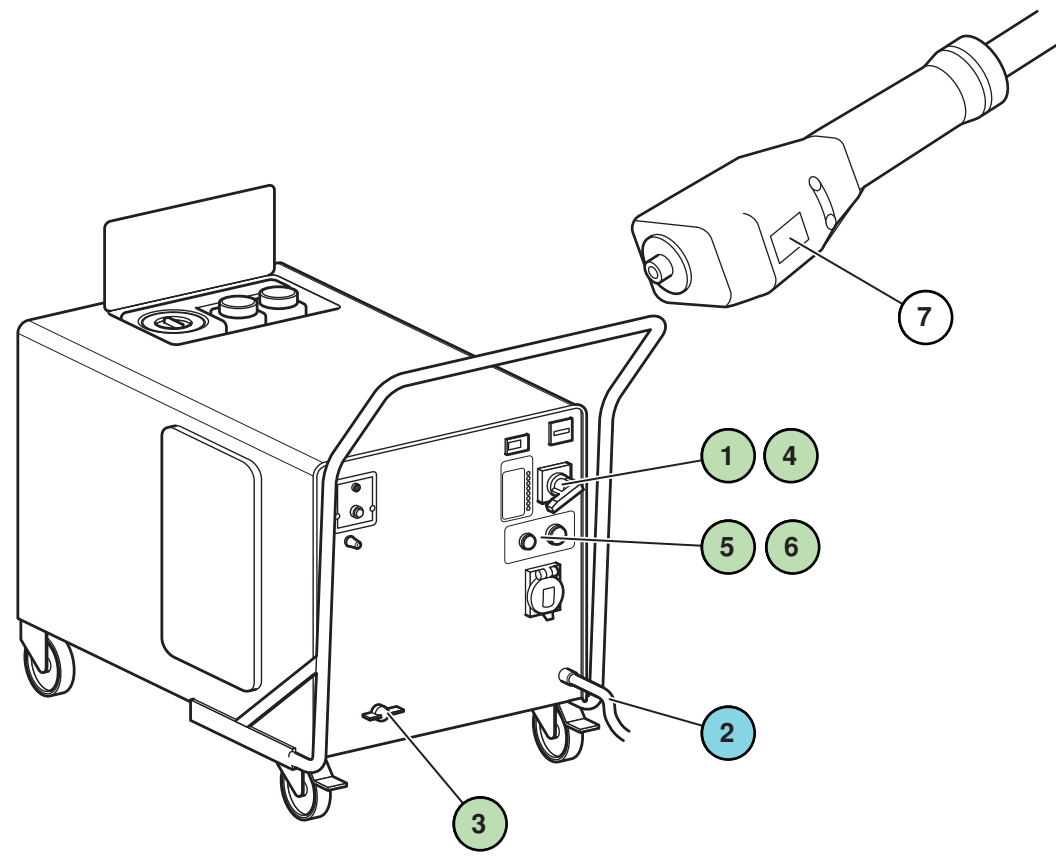

Note.

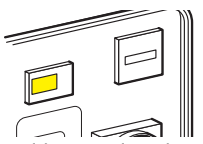

Pressure should never rise above 11 bar. If this occurs shut down immediately and refer to trouble shooting section.

Note.

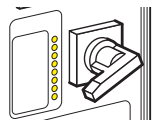

Pump and resistance lights will illuminate during warm up. Once unit is ready for use the lights will go out. Indicator lights will turn on and off periodically during use - this is normal.

7.

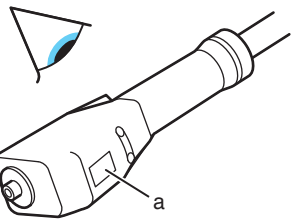

Ensure digital readout (a) on the handle is set to zero.

REA - Saturno Special 2 SHUT DOWN

Key

- Set/Move
- Remove/Replace
- Release/Secure

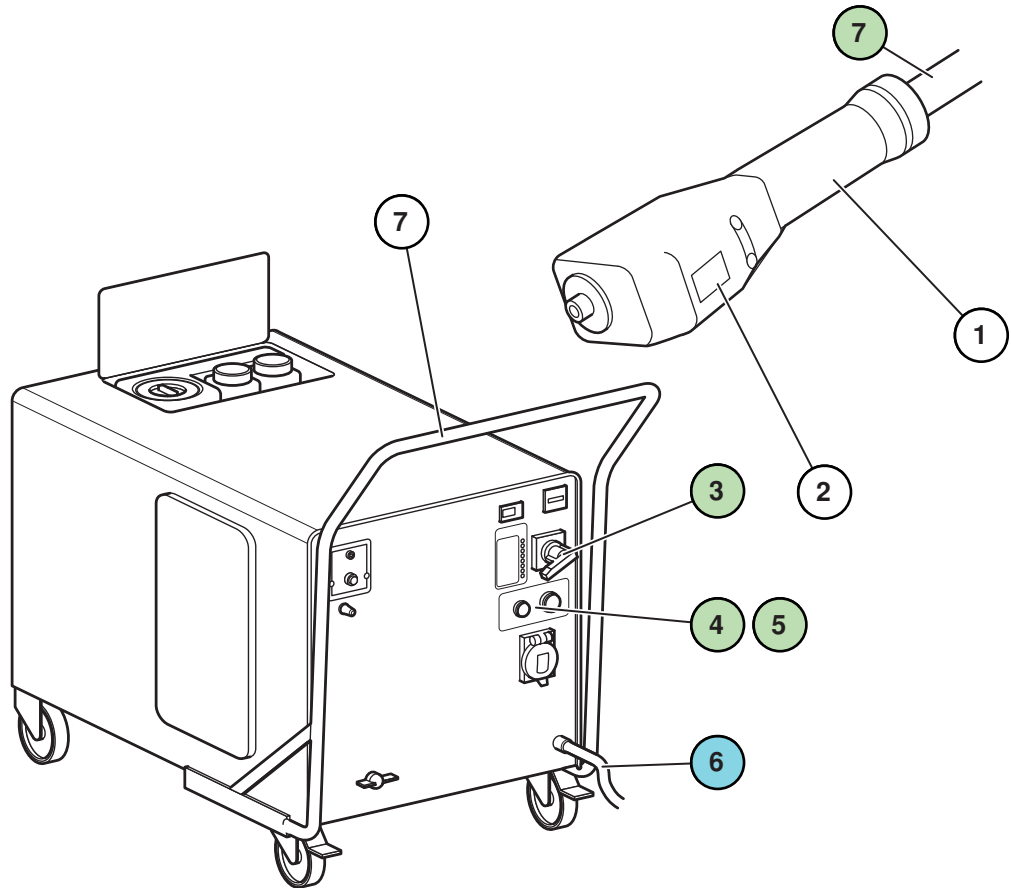

1.

Clean accessories with steam and detergent prior to shut down.

2.

Return Handle digital readout (a) to zero.

7.

Extend steam hose fully to eliminate kinks. Wrap hose around the handle unit. Do not kink hose.

3.

Turn 'Off' the main power switch.

4.

Turn 'STEAM' setting (a) to middle position.

5.

De-select detergent tank.

6.

Disconnect main power cord from electrical outlet.

REA - Saturno Special 2 SHUT DOWN

Key

- Set/Move
- Remove/Replace
- Release/Secure

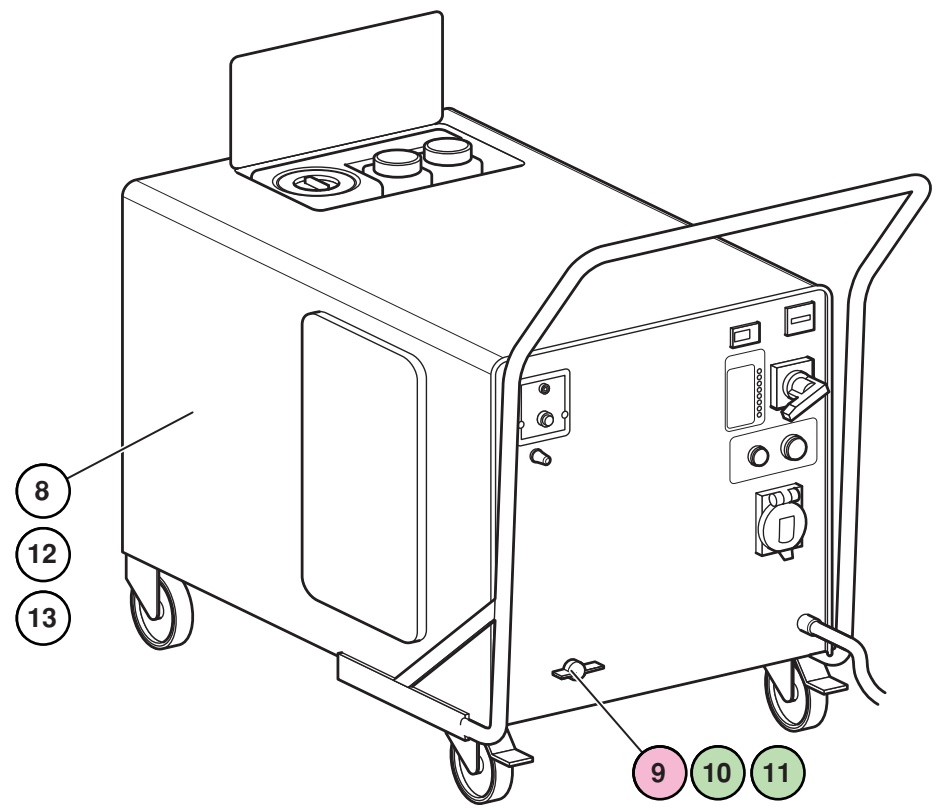

8.

Move unit to a appropriate area with drain to exhaust boiler.

13.

Cover machine when storing in a dusty environment.

9.

Place exhaust tool over the exhaust valve (a).

10.

Release the boiler exhaust valve quickly by turning 90° counter-clockwise. Steam will rapidly discharge from underneath the boiler. This is loud, notify others in area.

11.

Machine should be stored with the boiler exhaust valve in the open position.

12.

Do not leave the machine in temperatures lower than 0°C.

REA - Saturno Special 2 FILTER CLEANING

Key

- Set/Move
- Remove/Replace
- Release/Secure

- 1
- 2
- 3
- 4
- 5
- 6
- 7
- 8



1. Monthly

Rotate lid of water tank until the gap (a) aligns with one of the screws (b) and remove lid.

2.

Release and remove screws (a) x3.

3.

Remove filter.

4.

Wash filter thoroughly under running water from an approved source.

5.

Replace filter.

6.

Replace and secure screws (a) x3.

8.

Never leave the water tank without the filter and lid.

7.

Replace lid and secure.